



AEROMIST
SOLACE™
MISTING PUMP
Cool. Calm. Controlled.

PRODUCT MANUAL

Directory

1.	GENERAL INFORMATION.....	1
2.	SPECIFICATION.....	2
2.1	Dimensions.....	3
2.2	Identifying the Components	4
2.3	Part drawing.....	5
2.4	Part list.....	5
3.	Quick Set-up	8
3.1	Installation.....	8
3.2	A Framework Diagram of the Aeromist Solace Misting Pump	10
3.3	Infrared Transmission Remote Control Guide.....	11
4.	Safety Instructions	12
4.1	Danger 	12
4.2	WARNING 	12
4.3	CAUTION 	12
5.	Operation.....	14
5.1	Circuit logic diagram.....	14
5.2	The Specification of the PCB Electric Control Box	14
5.3	Introduction of the LCD Monitor.....	16
5.4	How to Operate the Misting Controller.....	17
6.	Troubleshooting	25
7.	Maintenance.....	26
7.1	Periodic Check and Inspection.....	26
7.2	The Procedure for Oil Change.....	27
7.3	The Procedure of Changing Filter Cartridge.....	29
7.4	The time to change oil	30
7.5	Oil Changing Interval (hours or months).....	32
7.6	Oil Selection.....	33
8.	Warranty	35

1. GENERAL INFORMATION

This manual contains important information for the correct use and maintenance of the misting pump. Please follow all instructions carefully. The manufacturer/supplier is not responsible for damage to persons, property, or the system if the equipment is used in ways not described in this manual.

This manual is intended for use by the operator or technician to ensure proper handling of the misting pump. The information provided does not override any current workplace safety regulations. Users must comply with local laws in the country of installation, in addition to following standard safety practices.

Do not operate the product if any damage or wear is visible that could affect its original safety conditions. Users or maintenance technicians must report faults to the supplier. This machine is designed for specific uses only. Do not modify or use it for any purposes other than those described.

All instructions, diagrams, tables, and content within this manual are considered proprietary technical documentation and are the exclusive property of TANONG Precision Technology Co. Ltd. No part may be shared with third parties without written authorization from TANONG Precision Technology Co. Ltd. Descriptions and images are for reference only and may change without notice. For further technical or functional details, contact the manufacturer or supplier.

IMPORTANT :

- Read the information in this booklet carefully, as it contains important instructions for the safe installation, operation, and maintenance of the pump.
- The manufacturer is not responsible for any damage to persons, property, or the machine itself if the pump is used in ways other than described in this manual.
- Store this booklet in a safe place and keep it available for future reference.
- Upon delivery, inspect the unit for any possible damage that may have occurred during transport.

Related Symbols and Meanings :



It indicates that improper use may result in death or serious injury.



It indicates that improper use may likely result in death or serious injury.



It indicates that improper use may cause serious injury and/or damage to the product and could lead to unexpected incidents.

2. SPECIFICATION

Aeromist Solace Misting Pump			
Model	Aeromist Solace Misting Pump		
Max. operating pressure	1000 PSI / 70 bar		
Flow rate	1/3 Hp	1750 RPM	● Solace 1 →.3 GPM (1.3 L/min) ≈16 PCs (.006"(0.15mm) nozzle)
	1/2 Hp		● Solace 2 →.6 GPM (2.5 L/min) ≈31 PCs (.006"(0.15mm) nozzle)
	3/4 Hp		● Solace 3 →1 GPM (3.8 L/min)≈48 PCs (.006"(0.15mm) nozzle)
	1 Hp		● Solace 5 →1.2 GPM (4.8 L/min)≈48 PCs (.006"(0.15mm) nozzle)
	1/3 Hp	1450 RPM	● Solace 1 →.3 GPM (1.1 L/min)≈14 PCs (.006"(0.15mm) nozzle)
	1/2 Hp		● Solace 2 →.5 GPM (2.0 L/min)≈25 PCs (.006"(0.15mm) nozzle)
	3/4 Hp		● Solace 3 →.8 GPM (3.2 L/min)≈40 PCs (.006"(0.15mm) nozzle)
	1 Hp		● Solace 5 →1 GPM (4.0 L/min)≈50 PCs (.006"(0.15mm) nozzle)
Motor	Total Enclosed, Single/Three Phase, 4P 110/220 V, 50/60Hz		
Dimensions	L×W×H : 22.52×14.65×13.35 in (572×372×339 mm)		
Weight	52.9~62.8 lbs (24~28.5 kg) (Depending on the model)		
Standard Components	<ul style="list-style-type: none"> ● Electric Solenoid Valve, Inlet ● Electric Solenoid Valve, Outlet ● LCD Control Panel ● 5" Filter ● Drought Switch Sensor ● Infrared Transmission Remote Control 		
Optional Accessories	<ul style="list-style-type: none"> ● External Control Box (16.4 ft, 49.2 ft, 65.6 ft) (5m, 15m, 20m) ● LCD panel Protector 		
Power cable	<ul style="list-style-type: none"> ● 3φ (PSE)300V,VCT .13 in (3.5mm)×4C×11.48 ft (3.5m) ● 1φ (PSE)300V,VCT .13 in (3.5mm)×4C×11.48 ft (3.5m) 		
Functions	<ul style="list-style-type: none"> ● Automatic Power-off With Drought Switch ● Automatic Power-off When Motor Overload ● Temperature & Humidity Surveillance ● Total Running Time Recorder ● 300 hours Maintenance Reminder ● Regulator with Internal By-pass design ● Mode 1 : 15 sec. Misting / 20 sec. Stop ● Mode 2 : 25 sec. Misting / 30 sec. Stop ● Mode 3 : 40 sec. Misting / 40 sec. Stop ● Mode 4 : Programmable ● Mode 5 : Weekly cycle set by user ● Mode 6 : Continuous Misting 		
REMARK	⚠ DANGER Forbidden to use outside the house on rainy days		
	✘ Strongly recommended to add water pressure motor		

2.1 Dimensions

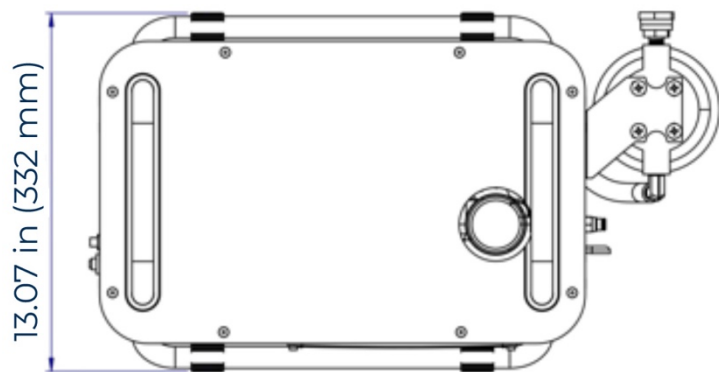
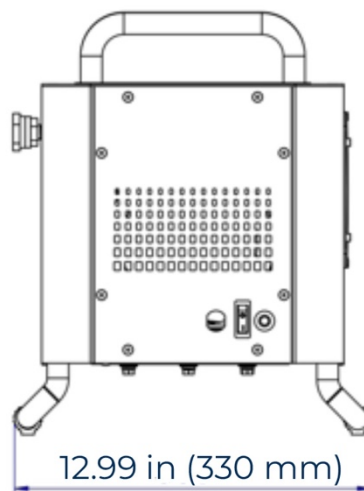
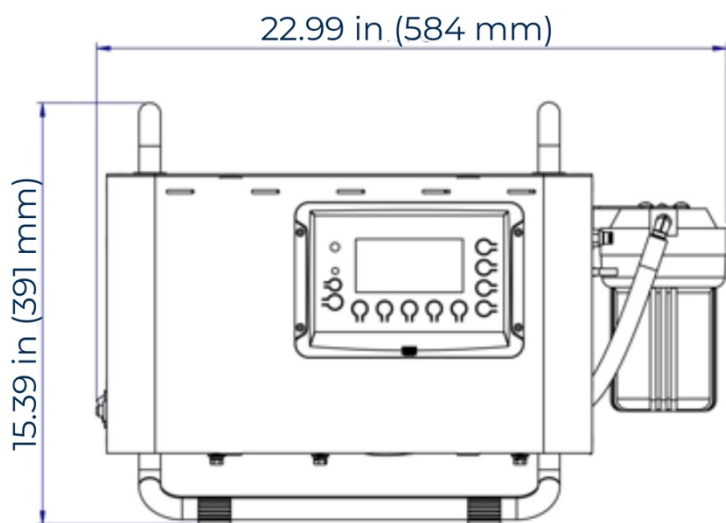

2.2 Identifying the Components

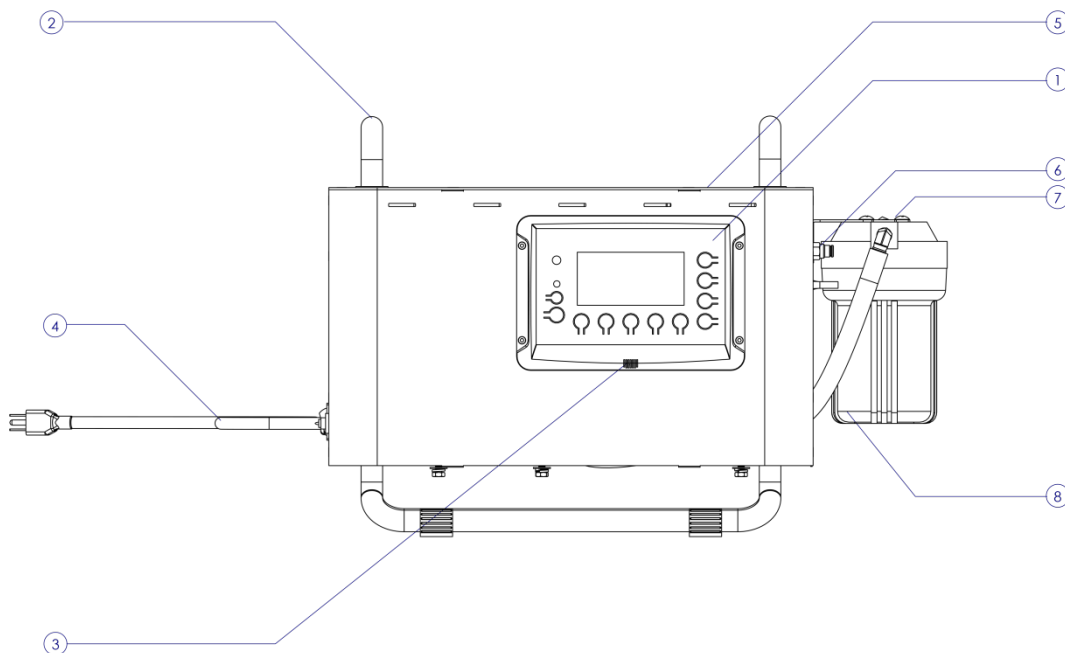

Description of parts			
1	LCD control Panel	5	Pressure Gauge
2	Flip handle	6	Quick Coupling, Inlet
3	Sensor for Temp. & Humidity	7	5" Inlet Water filter
4	Power Cable with Plug		

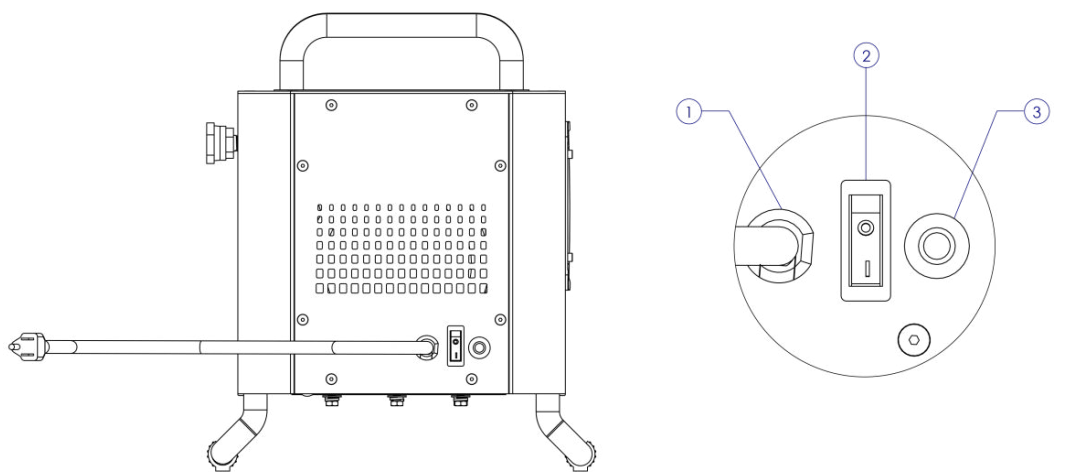

Description of parts			
1	Power Cable Port	3	Overload protector
2	Main Power Button		

2.3 Part drawing

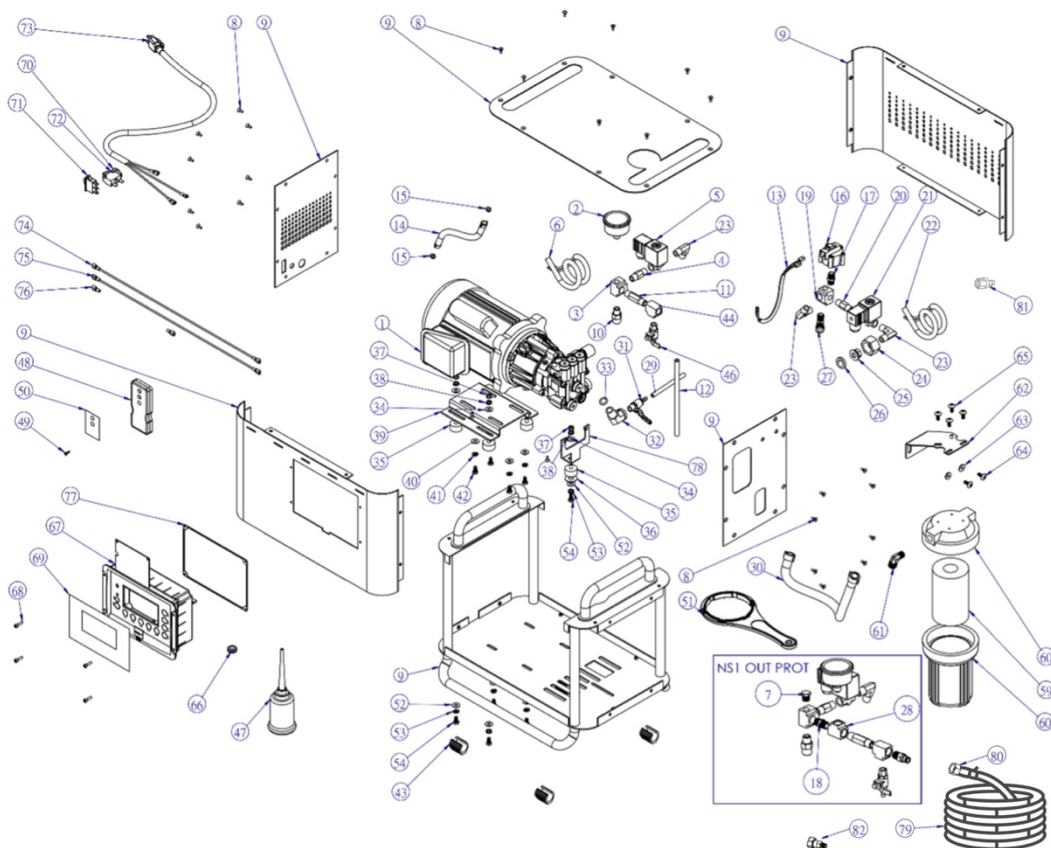

2.4 Part list

Pos.	Parts NO.	Parts Name	Quantity
1	2A-05-0416	Solace 1 Pump	1
	2A-05-0234	Solace 2 Pump	1
	2A-05-0333	Solace 3 Pump	1
	2A-05-0533	Solace 5 Pump	1
2	06-17-0006	Oil pressure gauge	1
3	059-C405-001	Connector	1
4	06-05-0503	Connector	1
5	A16-IMS9-002	Solenoid valve	1
6	11-01-0031	Power cord set (high pressure solenoid valve)	1
7	053-2800-001	Plug	1
8	06-01-2401	Screw	32
9	03-01-0034	Frame	1
10	059-C183-007S	Connector	1
11	059-C183-036	Connector	1
12	A14-C003-100	Tube	1
13	11-01-0006	Power cord	1
14	A03-D075-005	High pressure pipe	1
15	A01-B008-103	Connector	2
16	A16-IMS9-007	Low voltage switch	1

Pos.	Parts NO.	Parts Name	Quantity
17	059-C183-002	Connector	1
18	059-C183-002	Connector	1
19	059-C405-001	Connector	1
20	06-05-0503	Connector	1
21	A16-IMS9-003	Solenoid valve	1
22	11-01-0041	Power cord set (high pressure solenoid valve)	1
23	059-C203-002	Connector	3
24	06-02-8001	Nut	1
25	06-05-8002/1	Connector	1
26	04-06-0004	Packing	1
27	06-05-1503	Connector	1
28	059-C305-001	Connector	1
29	A03-P002-300	Hose	1
30	A03-D100-003	High pressure pipe	1
31	06-18-0007	Water outlet switch	1
32	059-C210-001	Connector	1
33	120-1218-000	O-ring	1
34	145-0104-002	Washer	5
35	06-10-0008	Washer	5
36	06-10-0002	Washer	1
37	146-0600-003	Nut	5
38	144-0600-002	Spring Washer	5
39	06-19-0002A	Motor holder	1
40	145-0104-002	Washer	5
41	144-0600-002	Spring Washer	5
42	140-0600-016	Screw	5
43	018-C000-001	U-Shaped Floor Glides Tubing Caps	4
44	059-C305-001	Connector	1
46	06-18-0007	Valve	1
47	06-31-0016	Refueling bottle	1
48	11-14-0024	Infrared remote control	1
49	142-0400-006	Screw	1
50	11-07-0004	Remote control sticker	1
51	A16-IMS9-A02	Filter Housing Wrench	1
52	145-0104-002	Washer	5
53	144-0600-002	Spring washer	5
54	140-0600-007	Screw	5
57	120-1117-000	O-ring	1
58	059-COM0-001	Quick connector	1
59	A16-IMS9-020	Filter	1
60	A16-IMS9-016	Water filter housing	1
61	06-05-1503	Connector	1

Pos.	Parts NO.	Parts Name	Quantity
62	A16-IMS9-024C	Fixed plate	1
63	145-0104-002	Washer	2
64	142-0600-004	Screw	2
65	148-0508-001	Screws	4
66	11-10-0010	Rubber sleeve	2
67	11-14-0025	LCD electric control box assembly	1
68	140-0400-005	Screw	4
69	11-07-0005	Button sticker	1
70	11-10-0011	Strain relief bushing	1
71	11-10-0012	Switch	1
72	11-04-1008	Overload relay	1
73	11-01-0033	Power cord	1
74	11-01-0034	Jump wire (white)	1
75	11-01-0036	Jump wire (white)	1
76	11-01-0035	Jump wire (blue)	1
77	04-06-0006	Packing	1
78	03-01-0024	Y-shaped support frame	1
79	26038	4 ft 3/8" OD Black lock-on hose	4
80	26104	Brass US hose female adapter	1
81	26040	1/4" to 3/8" Barbed connector from filter bowl to 4' US hose (79)	1
82	54009	1/4" Male to 3/8" high pressure lock-on adapter	1

3. Quick Set-up

3.1 Installation

3.1.1 Unpack the machine

- 3.1.1.1 Remove the Solace Misting Pump from the packaging and confirm all included accessories are present.
- 3.1.1.2 Check the machine to see if there is any damage.

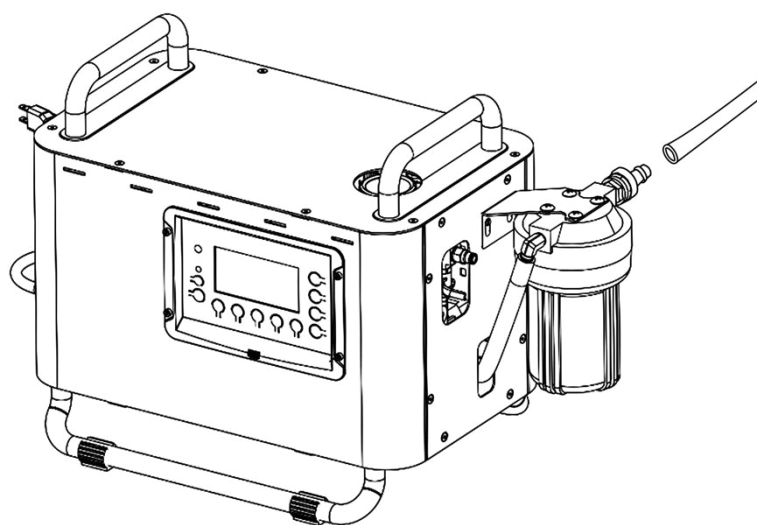

3.1.2 Install the water supply

- 3.1.2.1 Securely attach the open end of PN #26038- 4' 3/8" OD black hose to the inlet filter hose barbed connector PN #26040.

Note: This might require wetting the brass barbed connector (PN#26040) with a little dish soap to help slip the black end of the hose (PN#26038) onto the barbed end of the brass barbed hose inlet connection (PN#26040).

- 3.1.2.2 Connect US female brass bib adapter (PN #26104) to water supply faucet (see Diagram 3.2).

Note: Water from the faucet/source must always be on while the Aeromist Solace Misting Pump is running. Running the pump without water will void the warranty.

3.1.3 Connect the outlet

3.1.3.1 Connect the HP 3/8" high pressure hose to the HP 3/8" outlet connector fitting (PN #54009) on the machine.

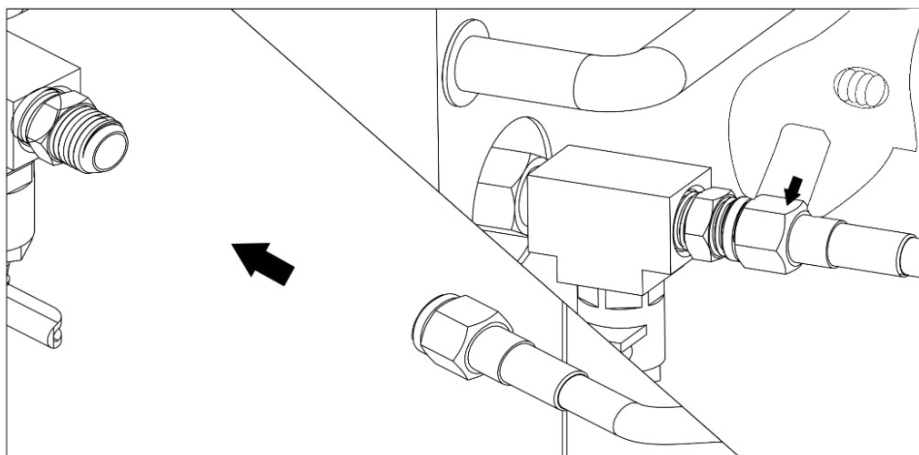

3.1.3.2 The outlet port has an extra vent cock. It is used to vent the air kept inside the pump, so the pump can reach its operating pressure quickly.

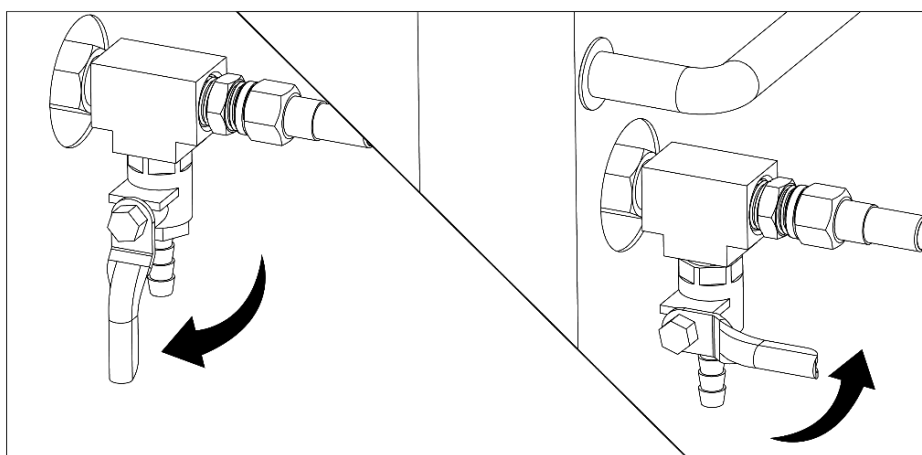

3.1.4 Verify the voltage and current capacity before plugging the power cable into the socket. Press the main power button to the "ON" position.

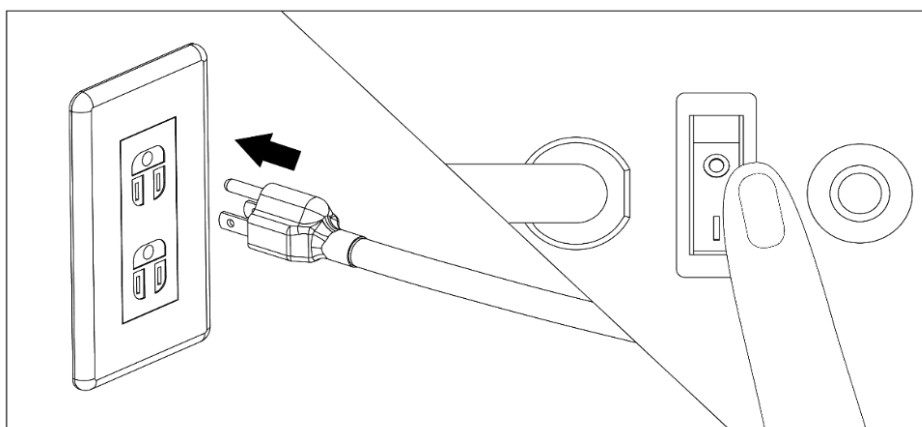

3.2 A Framework Diagram of the Aeromist Solace Misting Pump

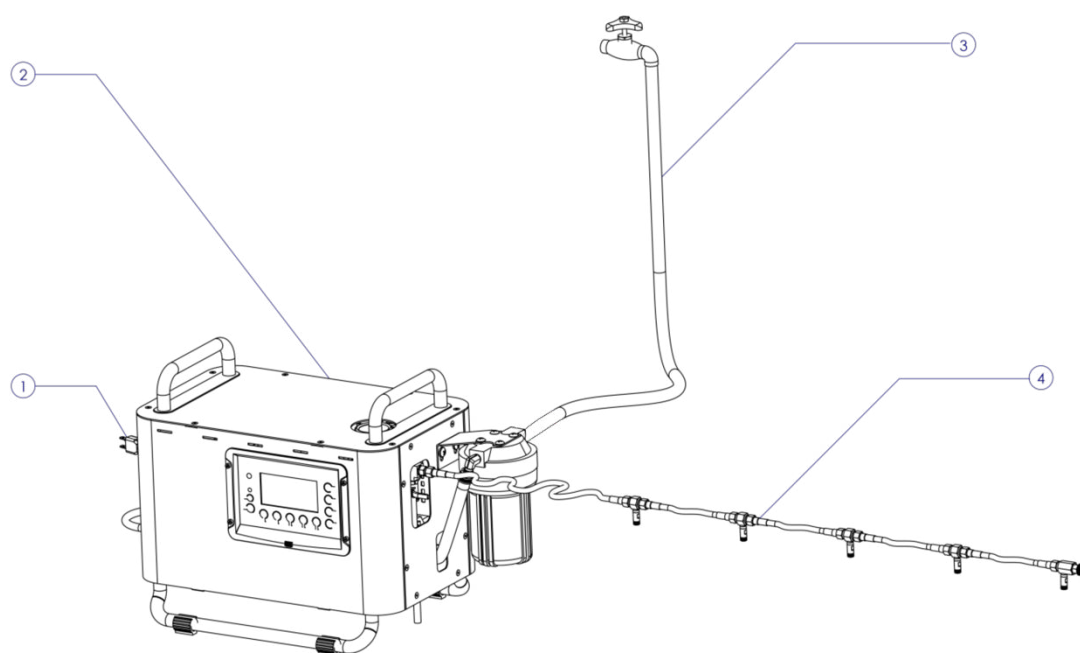

A Framework Diagram of Misting System	
1	Power Cable
2	Aeromist Solace Misting Pump
3	Water Supply Hose and US Water Bib Adapter (PN #26104 & #26038)
4	Nozzle Circuit

3.3 Infrared Transmission Remote Control Guide

Function Key Description of an Infrared Transmission Remote Control	
1	START button
2	STOP button

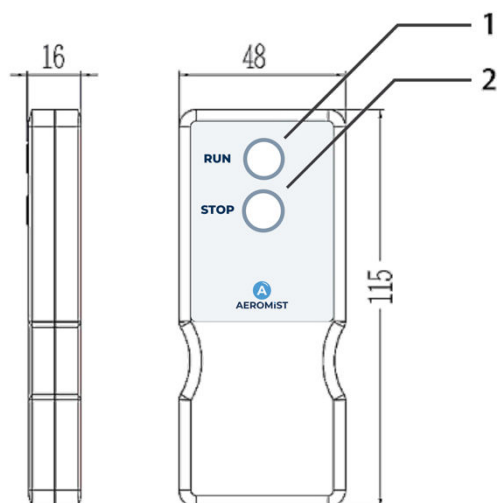

- 3.3.1 Secure the provided remote control holder to a wall or other fixed surface using screws.

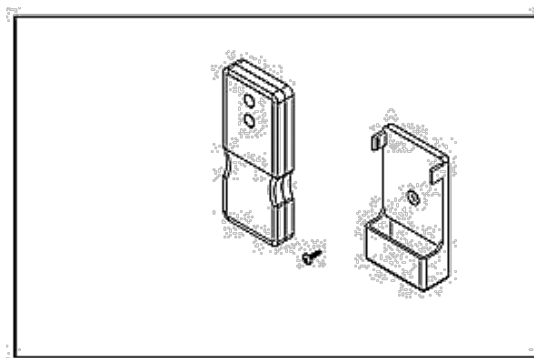

- 3.3.2 Remove the plastic cover from the back of the remote control unit. Insert two AAA dry batteries, then replace the cover.

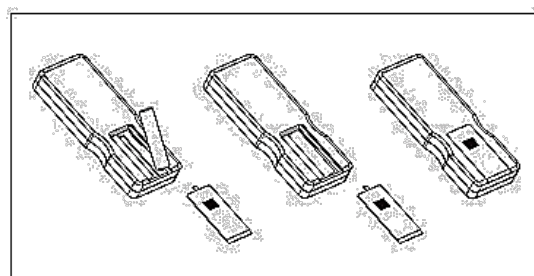

- 3.3.3 The ideal operating range for the infrared remote control is within 16.4 ft (5 M).

Performance may be significantly affected by strong light. It is strongly recommended not to use the unit under direct sunlight.

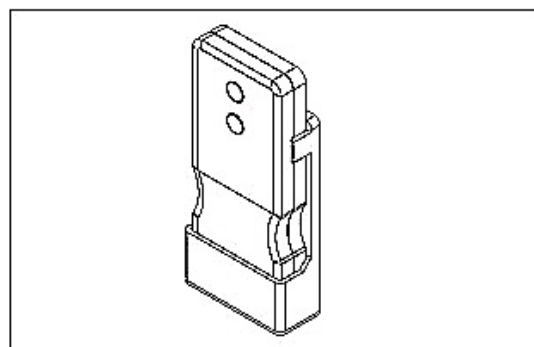

4. Safety Instructions

Before using this product, please read this manual and follow all safety guidelines and operating instructions. Failure to follow these instructions may result in personal injury and/or property damage.

The manufacturer cannot foresee all potential hazards that may arise during operation, inspection, or maintenance. Therefore, not all risks are covered in this manual. Remain alert to any unexpected conditions during use. For additional information, please contact your supplier.

This manual is considered part of the machine and should be stored in a safe place for future reference and quick access when needed.

4.1 Danger

- 4.1.1 This machine is forbidden to be used in rainy day.
- 4.1.2 Only trained professionals or qualified personnel are permitted to operate this machine. Operation by untrained individuals, including children and unqualified adults, is strictly prohibited.
- 4.1.3 The power source must be equipped with a residual current circuit breaker (RCCB) to prevent the risk of electric shock.
- 4.1.4 Do not touch or attempt to move the machine if the operator's hands are wet, shoes are removed, or if any electrical insulation failure is detected.
- 4.1.5 Install the machine on cement pavers or another solid, level surface that provides stable support. Keep the machine and surrounding area dry and away from open flames to prevent electrical short circuits or fire hazards.
- 4.1.6 To avoid potential damage or safety risks, do not operate the machine before thoroughly reading and understanding this operating manual.

4.2 WARNING

- 4.2.1 To ensure safe operation, the manufacturer recommends installing a discharge unloader at the end of the nozzle circuit. This device helps prevent system damage or injury in the event of a sudden pressure increase.
- 4.2.2 Do not open the cover or touch the motor or pump while the machine is operating. Moving parts may pose a safety risk.
- 4.2.3 Before starting the machine, ensure that all wires, plugs, and hoses are properly and securely connected.

4.3 CAUTION

- 4.3.1 Do not operate the machine under 32°F (0°C), unless anti-freezing agent is applied.

- 4.3.2** Before starting the machine, check that the lubrication oil level inside the pump is sufficient.
- 4.3.3** Use only a power source with the correct voltage (V), frequency (Hz), and sufficient current capacity, as specified for the machine.
- 4.3.4** Do not set up the operating pressure of the pump over 1000 PSI (70kgf/ cm²).
- 4.3.5** Do not operate the machine if there is insufficient water entering through the inlet port. Inadequate water supply can damage internal pump components and significantly reduce the machine's lifespan.
- 4.3.6** The water supply hose must have an inner diameter of at least 0.31 in (8 mm).
- 4.3.7** The power cable must not exceed 32.8 ft (10 m) in length, and any extension cable must have a conductor diameter of at least 0.05 in (1.25 mm).
- 4.3.8** Ensure the water supply flow rate is not less than 1.06 GPM (4 L/min). The inlet water pressure must be greater than 43.5 PSI (3 bar), such as from a pressurized water line.
- 4.3.9** Water temperature must not exceed 140°F (60°C) and should be properly filtered. Using clean, suitable water will help extend the overall lifespan of the misting system.
- 4.3.10** Before use, check whether the pump's lubrication oil has deteriorated, and ensure all water inlet pipes, outlet pipes, and fittings in the system are securely tightened.
- 4.3.11** The recommended number of nozzles for optimal misting performance varies based on the pump's flow rate. Using too few nozzles may cause overpressure, while too many nozzles can reduce pressure and result in poor atomization. Refer to the product catalog for detailed specifications.
- 4.3.12** Installing a valve at the end of the misting system is recommended. It allows trapped air to be released when the machine starts, helping the system reach the set pressure more quickly. Close the valve once the air has been fully purged.
- 4.3.13** During misting, inspect all nozzles to ensure none are blocked. If a nozzle is clogged, clean or replace it as needed.
- 4.3.14** During misting, inspect all pipes and connectors for leaks. If a leak is found, reinstall the connector or replace the faulty component.
- 4.3.15** For winter storage, run the machine dry for a few seconds to help drain any remaining water from the inlet and outlet pipes. Remove the high-pressure hose before storing the machine.

5. Operation

5.1 Circuit logic diagram

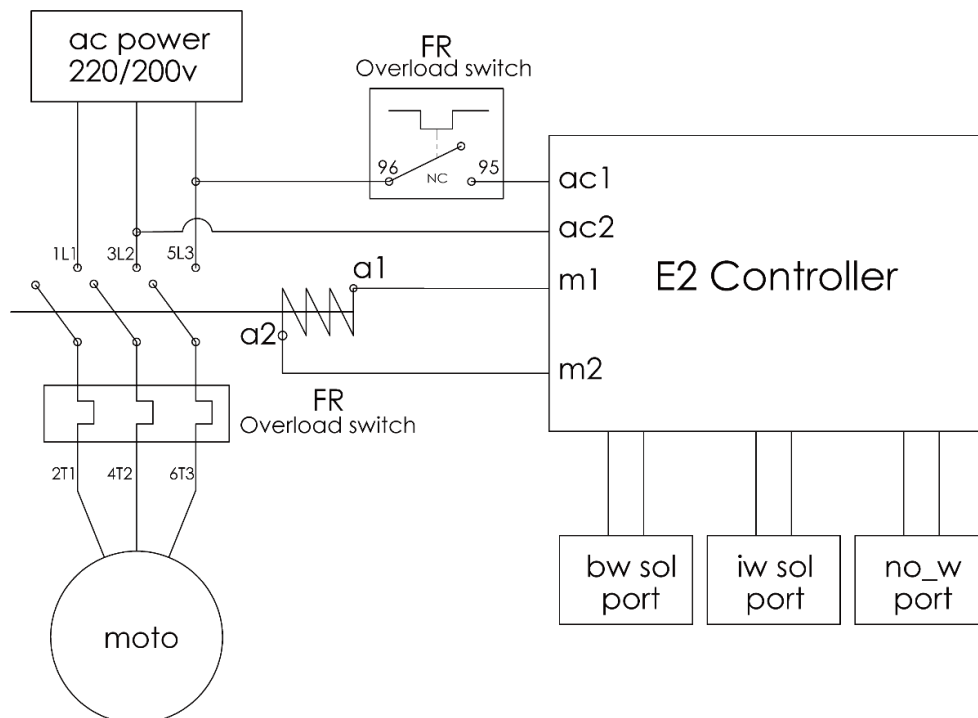









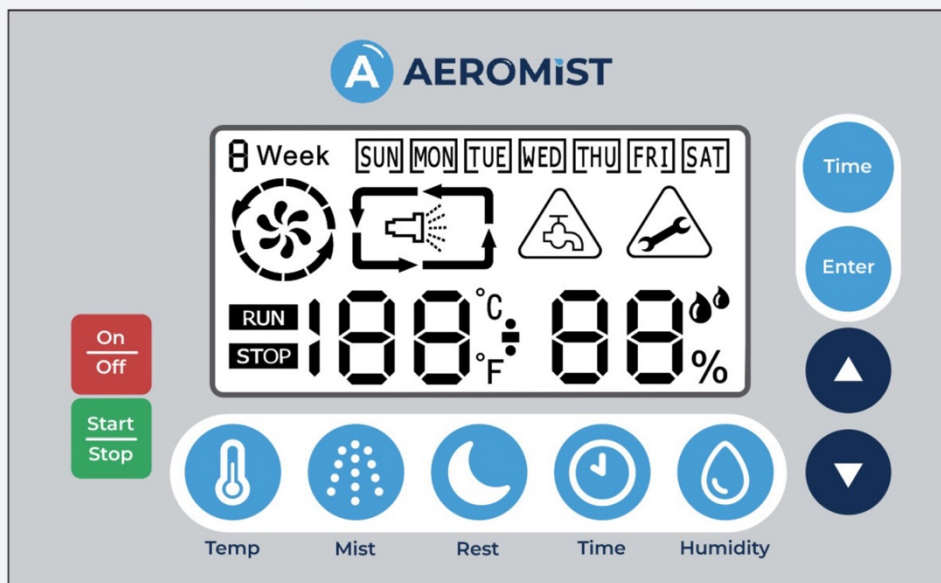



The magnetic switch will shut down automatically if the power is overloaded. The controller will be in standby mode and avoid any output immediately while switch on the power. It will be functioning again after the problem has been fixed.

5.2 The Specification of the PCB Electric Control Box

- 5.2.1 Adaptable power source includes AC 100V-240V, 50Hz or 60 Hz.
- 5.2.2 Ambient Temperature must be between 0-50°C, and 5% - 95% in relative humidity.
- 5.2.3 Internal power required is DC 12V.
- 5.2.4 3 sets of electric relays :
 - RY1 : drives the electric motor.
 - RY2 : drives the inlet solenoid valve.
 - RY3 : drives the by-pass solenoid valve.
- 5.2.5 Blue back-light LED.
- 5.2.6 Infrared Transmission Remote Control.
- 5.2.7 RTC time control, programmable.
- 5.2.8 6 operating modes available.
- 5.2.9 Both Celsius and Fahrenheit systems are available.
- 5.2.10 Detecting function for humidity.
- 5.2.11 Buzzer for timer.

GUIDE OF FUNCTION KEYS ON THE CONTROL PANEL



- | | |
|---|---|
|  ON/OFF MAIN POWER |  HUMIDITY CONTROL |
|  RUN/STOP MACHINE |  MODE CHANGE |
|  TEMPERATURE CONTROL |  ENTER SELECTED MODE |
|  MIST TIME SETTING |  UP BUTTON |
|  REST TIME SETTING |  DOWN BUTTON |
|  REST TIMER | |

5.3 Introduction of the LCD Monitor

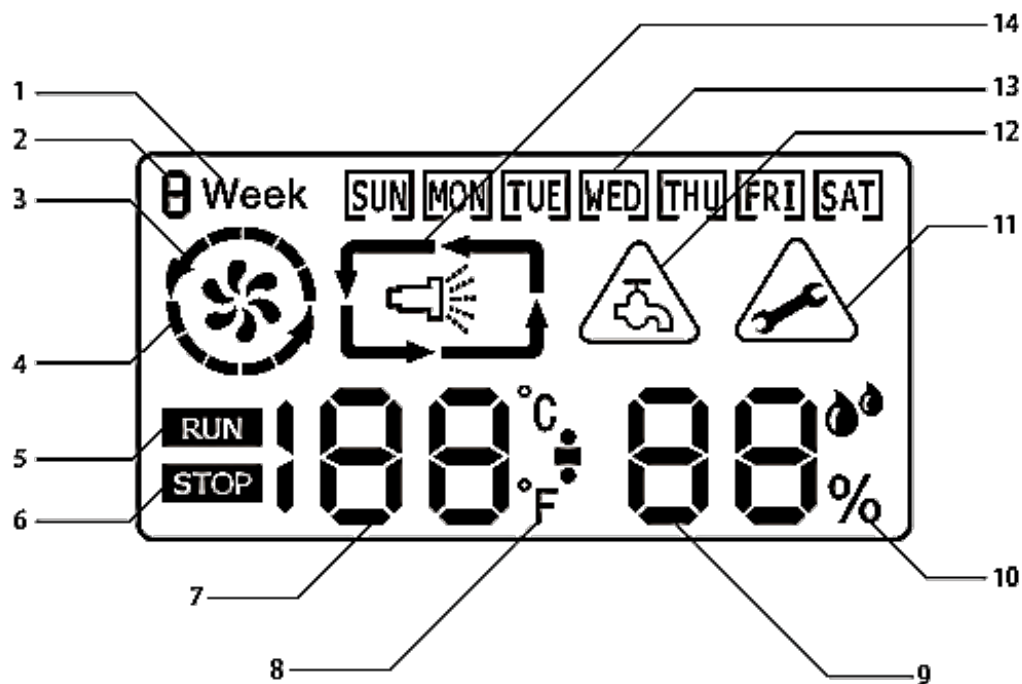

Introduction of the LCD Monitor			
1	Week Schedule	8	Display Celsius / Fahrenheit
2	Display the Mode Selected	9	Numerical Value (Humidity/Time)
3	Display for 1st Time Interval	10	Humidity display
4	Display for 2nd Time Interval	11	Display When Breakdown & Maintenance Required
5	Display during Running Status	12	Insufficient Water Supply
6	Display when Stop is Triggered	13	Specific Weekday
7	Numerical Value (Temp./Time)	14	Display for Misting / Rest



5.4 How to Operate the Misting Controller

5.4.1 Remote Controller, Buzzer, Function key Description

5.4.1.1 Push  one time => Shot down LCD, all functions stop, and RY3 will not stop until all procedures finish.

5.4.1.2 In any case when powered on, press "Run-Key" on remote control to activate the machine.

5.4.1.3 In any case when powered on, press "Stop-Key" on remote control to shut down the machine.

5.4.1.4 To adjust the volume of buzzer: First, press stop button to stop the machine, then press  UP-KEY or  DOWN-KEY for 2 seconds to start the function after hearing a buzzing.

- Press up /down button to increase/decrease the volume.

5.4.2 Power on and LCD Back-light Description

5.4.2.1 After pushing the main On/OFF button, the back light of the LCD will light up for 3 seconds and keep statuses as below :

- The machine is on STOP status, then as STOP.
- The machine is on standby or activating status, then as its original status before stopping the machine.

5.4.2.2 After powering on, the back light will be off if no further operation is executed within 30 seconds.

- Note : Before shutting down the machine or LCD control box (include abnormally shut down), the unit is recommended to be set as STOP in case any risks occur.

5.4.3  ON/OFF-KEY Description : (not the main external power supply switch)

5.4.3.1 When the machine is in standby mode or activating, push ON/OFF button one time =>LCD back light off and all functions shut down.

5.4.3.2 When the machine is powering off, push ON/OFF button one time=> power on the machine, and back light of the LCD is on.

5.4.3.3 The ON/OFF button is the only button with the function to shut down the machine (even the external POWER SUPPLY is on).

5.4.4  RUN/STOP-KEY Description

5.4.4.1 While the machine is in standby, push RUN/STOP one time =>Activate the machine, LCD shows a flashing "RUN".

5.4.4.2 While the machine is running, push RUN/STOP one time =>the

machine STOP and become STANDBY, LCD shows a flashing "STOP".

5.4.5 MODE-Key Description

5.4.5.1 When the machine is running, this key does not work.

5.4.5.2 When the machine is in the status of STOP/STANDBY, the user can push the MODE key and revolve the mode in 1 → 2 → 3 → 4 → 5 → 6 → 1 sequence.

5.4.6 ENTER-Key, UP-Key, DOWN-Key Description

Select the right function key to set up mode/function, push UP-key and/or DOWN-key to adjust right figure, then push ENTER key to confirm the selection.

5.4.7 TEMP-KEY : (The default set is off)



5.4.7.1 When the machine is in STOP status, push the TEMP-key one time and activate/disable temperature monitoring function.
Push the TEMP- key and revolve the mode in Activating temp monitoring → disable temp monitoring → activating temp monitoring (sequence).

5.4.7.2 The LCD display the temperature monitoring function as below :

- When users activate the temperature monitoring function, the numerical value lights up and "°C" flashes.
- When users disable the temperature monitoring function, the numerical value and "°C" both light up.

5.4.7.3 When the machine is in stop status, push the TEMP- key for 3 seconds and the LCD will show flashing numerical values and illuminate "°C".

Adjust the setting temperature by pushing UP or DOWN keys.

- Push  UP-key : 10 → 11 → 12 → ... → 60
- Push  DOWN-key : 60 → 59 → 58 → ... → 10
- After select the temperature, either push TEMP key one time or wait for 15 seconds to confirm the setting.

5.4.7.4 The temperature monitoring function works as below :

Activate the machine : When the ambient temperature is equal to or higher than the set temperature plus 2 degree, the "°C" will flash.

5.4.7.5 The setting range is between 50°F (10°C) ~ 140°F (60°C) and default value is 84°F (29°C).

5.4.7.6 The highest sensible temperature is 150°F (65°C).

5.4.7.7 The temperature monitoring function applies to all modes.



5.4.8 HUMIDITY-KEY : (The default set is off)

5.4.8.1 When the machine is in STOP status, push the key one time and activate/ disable humidity monitoring function.



Push the HUMIDITY- key and resolve the mode in Activate humidity monitoring → disable humidity monitoring→ activating humidity monitoring sequence.

5.4.8.2 The LCD displays the humidity monitoring function as below :

- When users activate the humidity monitoring function, the numerical value lights up and “%” flashes.
- When users disable the humidity monitoring function, the numerical value and “%” both do not flash.

5.4.8.3 When the machine is in stop status, push the key for 3 seconds and LCD will show flashing numerical value and light-up “%”.

Adjust the setting humidity by pushing UP or DOWN keys

- Press  : 30 → 35 → 40 → ...→ 95
- Press  : 95 → 90 → 85 → ...→ 30

5.4.8.4 After selecting the humidity, either press HUMIDITY key one time or wait for 15 seconds to confirm the setting.

5.4.8.5 The humidity monitoring function works as below :

- The temp monitoring function is prior to humidity monitoring function.
- Activate the machine : When the ambient humidity is equal to or lower than the set humidity minus 3%, the numerical value and “%” both flash.
- Stop the machine : When the ambient humidity is higher than the set humidity, the numerical value light up and “%” flash.



5.4.8.6 The setting range is between 30% ~ 95%. The default humidity is 70%.

5.4.8.7 The humidity monitoring function applies to all modes.



5.4.9 MIST-KEY

5.4.9.1 When the machine is in STOP status, select mode 4 to set the mist time.

5.4.9.2 Set “Minute” by pushing UP or DOWN keys.

- Press  : 00 → 01 ...→ 57 → 58 → 59
- Press  : 59 → 58 ...→ 02 → 01 → 00

5.4.9.3 After setup of the “Minute”, press ENTER  for further “Second” setting by pushing UP or DOWN keys.

- Press  : 00 → 01 ...→ 57 → 58 → 59
- Press  : 59 → 58 ...→ 02 → 01 → 00

- Note : If the “Minute” is set as 0, the setting interval for “Second” is 15 sec.

5.4.9.4 The MIST key  will light up to show a misting status.



5.4.9.5 Push MIST key one time or wait for 15 seconds to confirm and quit the setting.

5.4.9.6 The default value is 【One minute】 and 【Zero second】 .



5.4.10 REST-KEY

5.4.10.1 When the machine is in STOP status, select mode 4 to set the rest time.

5.4.10.2 Set “Minute” by pressing UP or DOWN keys.

- Press  UP-KEY : 00 → 01 ...→ 57 → 58 → 59
- Press  DOWN-KEY : 59 → 58 ...→ 02 → 01 → 00

5.4.10.3 After setting "minutes", press  to make further "second" settings and set by pressing UP or DOWN key.

- Push  UP-KEY 1 : 00 → 01 ...→ 57 → 58 → 59
- Push  DOWN-KEY 1 : 59 → 58 ...→ 02 → 01 → 00

5.4.10.4 The REST key  will light up to show misting interruption.

5.4.10.5 Press REST key one time or wait for 15 seconds to confirm and quit the setting.

5.4.10.6 The default value is 【One minute】 and 【Zero second】.

5.4.11  TIME-KEY -The default value is 【One minute】 and 【Zero second】

5.4.11.1 No matter if the machine is running or stopped, the LCD will show the real time when pressing the  key.

5.4.11.2 When the LCD is showing the real time, press TIME key one time or wait for 15 seconds, the system will go back to show temperature and/or humidity again.

When the machine is in STOP status, press the TIME key to show the real time and then ENTER key to set the time.

- Push the ENTER key and revolve the module in WEEK → HOUR → MINUTE → WEEK sequence.

5.4.11.3 Press  UP key to add up as below :

- Week : SUN → MON → TUE → WED → THU → FRI → SAT → SUN (in sequence)
- Hour : 00 → 01 → 02 → ... → 23 → 00
- Minute : 00 → 01 → 02 → ... → 59 → 00

5.4.11.4 Press  DOWN key to decrease progressively as below :

- Week : SUN → SAT → FRI → THU → WED → TUE → MON → SUN (in sequence)
- Hour : 00 → 23 → 22 → ... → 01 → 00
- Minute : 00 → 59 → 58 → ... → 01 → 00

5.4.11.5 Push TIME key one time or wait for 15 seconds to confirm and quit the setting.

5.4.12  Definition of Misting Mode

- Mode 1 : Misting 15 sec. and rest 20 sec.
- Mode 2 : Misting 25 sec. and rest 30 sec.





- Mode 3 : Misting 40 sec. and rest 40 sec.
- Mode 4 : Programmable, refer to 5.5.9. and 5.5.10
- Mode 5 : Weekly cycle set by user.
- Mode 6 : Continuous Misting.

5.4.13 MODE 5 Weekly Cycle Setting :

5.4.13.1 When the machine is in STOP status, press  key for at least 3 seconds to set the weekly cycle.

5.4.13.2 Set demand period (2 periods a day, totally 14 periods per week)

by pushing  UP or  DOWN keys. The selected "weekday" will flash.

- The period revolves in sequence as: SUN →  →  → MON →  →  → TUE.
- Whenever select a specified period, the system will show RUN and STOP setting in sequence.

5.4.13.3 When you select the option you want to set, press  ENTER-Key to enter the period to set.

5.4.13.4 Use the up and down keys to select the "Hour" setting that you want to activate. The setting value will be displayed in flashes. After setting, press  ENTER-Key once.

5.4.13.5 Use the up and down keys to select the "Minute" setting that you want to activate. The setting value will be displayed in flashes. After setting, press  ENTER-Key once.

5.4.13.6 Use the up and down keys to select the "Hour" setting that you want to stop. The setting value will be displayed in flashes. After setting, press  ENTER-Key once.

5.4.13.7 Use the up and down keys to select the "Minute" setting that you want to stop. The setting value will be displayed in flashes. After setting, press  ENTER-Key once.

5.4.13.8 Save the setting and return to 5.5.13.2 to select another weekday and period.

5.4.13.9 There are two periods for every weekday. Period 1  , Period 2  .

5.4.13.10 The setting RUN and STOP data will not be saved until both options are set. At any time, when users press  TIME key or wait for 15 seconds without setting new value during the setting procedure, the system will neglect current setting.

To save the current setting, the time of weekday's RUN and STOP must be set completely. Then, go back to weekday option before push TIME key or wait for 15 seconds to save the setting.

- The whole setting procedure is as below : SUN (whatever day)
→ RUN/STOP → Period options → HOUR setting → MINUTE setting → SUN

5.4.13.11 When Mode 5 activates, the machine displays 5 understand by status.

5.4.13.12 **The LCD will show X WEEK (X stand for current mode number as 0, 1, 2, 3, 4) under mode 5.**

5.4.13.13 When both Period 1 and Period 2 are selected, Period 1 is prior to Period 2 as the chart below shows.

Priority of the time within different period.

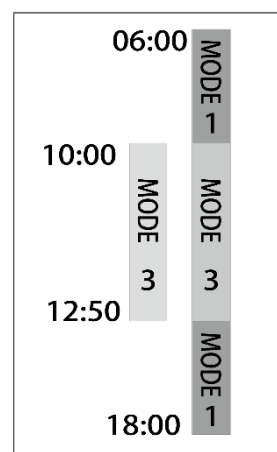

5.4.13.14 Attention : If the mode is selected as 0 in a specified period, the machine will not be activated.





5.4.13.15 The default value the manufacturer set:

DAY	SUN	MON	TUE	WED	THU	FRI	SAT	Remark
Period 1	08:00 0 ~11:30	08:00 0 ~11:30	08:00 0 ~11:30	08:00 0 ~11:30	08:00 0 ~11:30	08:00 0 ~11:30	08:00 0 ~11:30	Time of the period and mode can be set by user
Mode	1	1	1	1	1	1	1	
Period 1	13:30 ~17:30 0	13:30 ~17:30 0	13:30 ~17:30 0	13:30 ~17:30 0	13:30 ~17:30 0	13:30 ~17:30 0	13:30 ~17:30 0	
Mode	1	1	1	1	1	1	1	

5.4.14 Insufficient Water Supply Warning

- 5.4.14.1 When water supply is insufficient, the warning icon , will flash. The buzzer calls one time for 0.5 second. The system STOP for standing by.
- 5.4.14.2 To relieve the WARNING, please check and eliminate the insufficient-water-supply condition. The system automatically detects the feed-in water, relieves the warning, and RUNs the machine.

5.4.15 ENGINEERING MODE and MOTER Running Warning

- 5.4.15.1 When the machine is standing by, press  and  at the same time for 3 seconds, then the system enters ENGINEERING MODE.
- 5.4.15.2 At any time, press  ENTER key, the option of ENGINEERING MODE resolves as 1 → 2 → 3 → 1 in sequence.
- 5.4.15.3 During setting up, the system will go back to original frame either by pushing MODE key one time or doing nothing for 15 seconds. The data will be automatically saved before quitting the mode.
- 5.4.15.4 When total running time reach up to 300 hours, the maintenance icon lights up and the buzzer calls for about 0.5 seconds. The action will not influence any function.
- 5.4.15.5 The way to relieve Maintenance Warning : After maintenance, enter into ENGINEERING MODE and go to mode 2, push  DOWN key 3 seconds to cease the warning.

5.4.15.6 Operating Mode

Mode	Description	Setting Procedure
1	Celsius / Fahrenheit Alter	Push TEMP key one time to switch Celsius / Fahrenheit system. After changing, the temperature monitoring standard will alter accordingly.
2	Total Running Time for MOTOR	Push DOWN key 3 seconds, then the existed running time will be eliminated (normally, be set after maintenance)
3	Sum up of the Total Running Time of the System	The sum up value can't be renewed. If the user changes the machine's motor or pump, check with the dealer to return to ZERO.

6. Troubleshooting



Before troubleshooting, please turn off the power before performing maintenance work to prevent electric shock.

Problem	Probable Cause	Solution
No mist coming out of nozzle	<ul style="list-style-type: none"> • The misting nozzle gets blocked. • Air is in the line. • Air gets into the pump. • The valves worn out or the pump is clogged. • Misting nozzles are worn out. 	<ul style="list-style-type: none"> • Clean the nozzle, if it doesn't work, change the nozzle. • Release the air. • Tighten all joints connected to the water inlet. • Check or change the O-ring of all joints if necessary. • Change or clean the valves, then reset the pump. • Change misting nozzle.
The pump is failing to absorb water	<ul style="list-style-type: none"> • No water supply. • The valves wore out or the pump is clogged. • Air got into the pump. • The water filter is blocked. • The seals or packings inside the pump are worn out. 	<ul style="list-style-type: none"> • Turn on the water faucet. • Change or clean the valves, then reset the pump. • Tighten all joints connected to the water inlet. • Check or change the O-ring of all joints if necessary. • Clean the water filters. • Replace the worn out seals or packings.
Unstable output pressure	<ul style="list-style-type: none"> • The pump's regulator is worn out or got stuck. • The pump's valves wore out. • The seals or packings inside the pump wore out. 	<ul style="list-style-type: none"> • Dismantle the regulator, clean and/or change related parts, if necessary. • Change valves. • Replace the worn out seals or packings.
Abnormal noise or vibration	<ul style="list-style-type: none"> • The lubrication ability from oil is insufficient. • Water pipe and nozzle circuit got blocked. • Water supply (including inlet pressure) is abnormal. 	<ul style="list-style-type: none"> • Add or change oil. • Clean or change nozzle and/or water pipes. • Check water supply line, clean, or reset it.
Oil or water leaks	<ul style="list-style-type: none"> • The seals or packings inside the pump wore out or are damaged. 	<ul style="list-style-type: none"> • Replace the worn out or damaged seals or packings.

Motor cannot run	<ul style="list-style-type: none"> • The voltage of the power supply is not stable. • The wire is too long and causes voltage and current to drop. • The built-in thermos switch activates to protect the motor. • The setting of the control panel restrains the motor. 	<ul style="list-style-type: none"> • Apply a constant voltage regulator and/or shorten the extension of the power cable. • Check that operating pressure is within a proper range. • Run the machine in a ventilated space. • Refer to the manual and check all settings are correct.
------------------	--	---

7. Maintenance

7.1 Periodic Check and Inspection

Items	Period				
	Before operation	50hr	100hr	200hr	300hr
Main Machine Structure					
Check All Components are	◆				◆
Check Water Line is without	◆				◆
Check Pump Oil is without	◆				◆
Abnormal Sound and Vibration	◆				◆
Frame and Cover Damage	◆				◆
Important & Safe label Check	◆				◆
Hose/Pipe					
Check Connectors and Hose Damage	◆			◆	
Check and Clean Inlet Water	◆			◆	
Check Nozzle Leakage or	◆			◆	
Electric Wire					
Check for Power Circuit	◆			◆	
Check if Electric Cord is Loose	◆			◆	
Accessory hose					
Check and clean the Pressure					◆
High Pressure Pump					
Check Oil Quantity	◆		◆		
Change Oil		◆ (Only for the first time)			◆
Check pressure Relief Valve					◆
Change the Oil Seal					◆
Check the Plunger					◆
Motor					
Check the Isolation on the					◆



DANGER Before doing checks, make sure that power has been turned off.



WARNING The marks mean that the item requires use of professional skills and tools to measure.



- The interval mentioned above does not mean to the time of durability.
- The checklist is only for reference, actual change time should be judged by frequency of use.

7.2 The Procedure for Oil Change



DANGER To avoid any possibility of electric shock, please power off the machine before doing any maintenance or inspection.



- Without regular maintenance and failure to change the oil regularly or replace the oil that does not meet the requirements, will cause damage to the machine parts or shorten the service life.
- When changing the engine oil, please make sure to remove the old oil, otherwise too much old oil will be mixed, which may affect the quality of the new oil or deteriorate.
- Make sure to change the oil when the engine is cold, and the pump must be kept in a horizontal position. The angle of inclination should not exceed 5° in all directions to avoid oil expansion and misjudgment of oil level.

7.2.1 Open the discharge cock at the end of the nozzle circuit and clean the whole pipe system.

7.2.2 Remove the water supply hose and high pressure misting hose, then wipe all components.

7.2.3 Check the bottom of the machine to see if there is any leakage of oil from pump body.

7.2.4 Check the oil inside the pump. If the oil quantity is inadequate, refill it. If the quality of oil is not good (oil shows white color or is too dirty and/or viscous), change it.

7.2.5 Oil must be changed after first 50 hours of operation and then be changed every 300 running hours. Use gear oil VG68 or equivalent. The amount of oil added each time depends on the model, but it must be between the low point to the middle point of the oil detection lens. The oil capacity is around 120ml or 150 ml (**ISO VG68 · VG 100 or SAE GEAR 80W90**).

- **Solace Misting 1 / Solace Misting 2 Please add about 120 ml of oil.**
- **Solace Misting 3 / Solace Misting 5 Please add about 150 ml of oil.**

7.2.6 The oil replacement procedure is as follows:

7.2.6.1 Remove the refill screw on the top of the pump (release the air and drain out the oil).

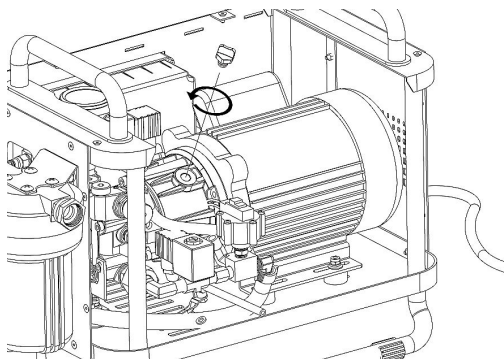

7.2.6.2 Prepare a vessel to collect aged oil before open drain cock in the bottom of the pump.

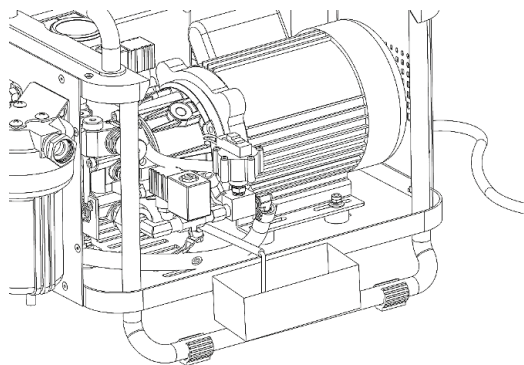

7.2.6.3 Close the drain cock, then add oil through refill hole.

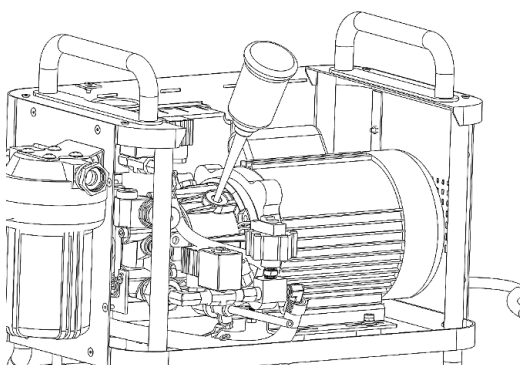

7.2.6.4 Tighten the refill screw.

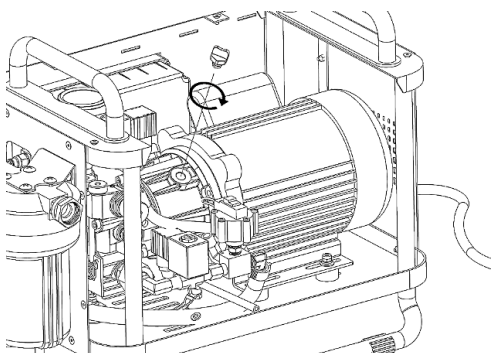

7.2.7 After maintenance, please recheck that all bolts, screws, and connectors are all tightened and fixed firmly.

! CAUTION

If the screws are not locked properly, it will cause damage to the machine parts or shorten the service life of the product.

7.3 The Procedure of Changing Filter Cartridge

! CAUTION

- Check the inlet water filter every 500 running hours or every three months.
- Change the filter cartridge if the filter get blocked or is too dirty.
- If the user adds one more filter, the manufacturer recommends that it is changed (from water faucet side) every three months, and six months for the second one.

7.3.1 Use the special spanner to turn the filter housing anticlockwise, then remove the housing.

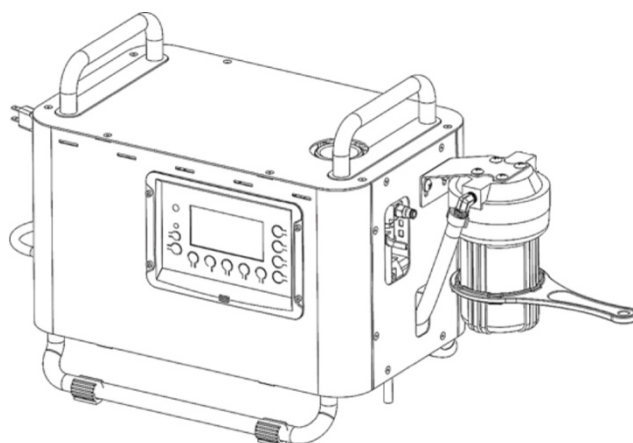

7.3.2 Replace the filter cartridge with a new one, then turn the housing clockwise to fix the filter back with the spanner.

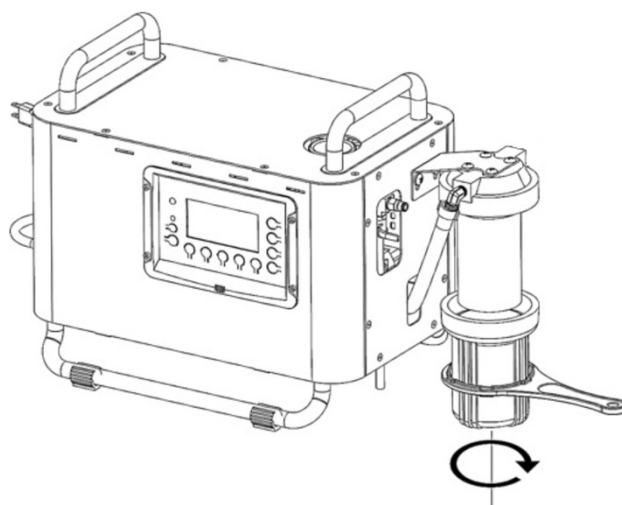

7.4 The time to change oil

Question	Reason	Method
<p>The effect of oil selection, time of change, and working environment on machine.</p>	<ul style="list-style-type: none"> • Change the oil according to operating hours or at regular service intervals. Failure to replace oil on time may lead to component damage due to reduced lubrication. 	<ul style="list-style-type: none"> • Change oil regularly or whichever occurs first. (see Chapter 7.5)
	<ul style="list-style-type: none"> • 1. Using improper or inferior quality oil (e.g. recycle oil) cannot achieve proper lubricant function and component protection. • 2. If used oil is not drained completely whenever changing oil, the left impurities of used oil will be dissolved in new oil, accelerating the oil deterioration. • 3. Do not mix with different group oils as their chemical composition and additives are different. Mixed oil could cause deterioration. • 4. Avoid using PAG oil. <ol style="list-style-type: none"> a. Most common rubber and plastics are closed to polarity that will be affected by PAG, leading to swelling or shrinkage. b. The paint will be eroded and then peeled off by PAG oil. c. Light metals (e.g. Aluminum alloy) will be eroded or cracked by PAG under stress. d. PAG oil is hydrophilic; thus, water cannot be filtered out by the filtering system. 	<ul style="list-style-type: none"> • 1.1 Use the manufacturer or other qualified brands. Please avoid using inferior oil such as recycled oil. • 2.1 Whenever changing the oil, ensure the used oil is drained completely for the new oil. • 3.1 For replacing oil with different group oil, the used oil needs to be drained completely, then wash the oil tank with replaced oil before refilling it. • 4.1 Avoid using PAG oil.

Question	Reason	Method
<p>The effect of oil selection, time of change, and working environment on machine.</p>	<ol style="list-style-type: none"> 1. The interval between the highest and the lowest temperature will directly affect the liquidity and lubricity of oil. 2. Under critical work environments (e.g. heat, stuffy, directly exposed under sunlight or rain, dusty, high humidity, bad air quality), the selection of oil and time of changing oil will directly affect the maintenance and lubricity of the machine. 	<ul style="list-style-type: none"> • 1.1 Please select the oil with adequate viscosity according to workplace environment to have best lubricity and protection. (see Chapter 7.6) • 2.1 The time of changing oil is based on regular operation. Operator should consider the effect of workplace environments, temperature, and humidity for increasing or decreasing the interval of changing oil, and should also shorten the interval, depending on the condition of the liquidity, impurity, odor, and deterioration.
	<ol style="list-style-type: none"> 1. If the operator uses the machine under constant overpressure, it will lead to loss of oil lubricity rapidly. 2. If the machine is left unused for long time or only used rarely, it will lead to oil deterioration by oxidation or even cause internal components to rust. 	<ul style="list-style-type: none"> • 1.1 If operational condition is strict such as operation in constant overpressure, then the interval of changing oil should be shortened. ✘ The performance of the machine is limited. Overpressure operation will lead to component damage and reduce life of the machine. Please follow the instructions of pressure specification for the sake of long- term use. • 2.1 Please change the oil regularly when the machine remains unused for an extended period. • 2.2 If the machine needs to be used after a long-term unused status, please check the internal components and change oil. • 2.3 If the components are rusty, do not use it and return it to the manufacturer.

7.5 Oil Changing Interval (hours or months)

Oil Type Interval Frequency	Above VG68 Mineral base	Above VG68 Semi synthetic base	Above VG68 synthetic base	Remark
First time use	50 hr. or 1 month	50 hr. or 1 month	50 hr. or 1 month	<ul style="list-style-type: none"> Initial use causes wear-in of internal components, which may produce metal particles. It is important to change the oil after this break-in period.
Monthly average 8 hr. /days above	500 hr. or 2 months	600 hr. or 2.5 months	700 hr. or 3 months	<ul style="list-style-type: none"> For reference only. Workplace conditions and environmental factors should also be taken into consideration.
Monthly average 2 hr. /days above	300 hr. or 1.5months	400 hr. or 2 months	500 hr. or 2.5 months	<ul style="list-style-type: none"> For reference only. Workplace conditions and environmental factors should also be taken into consideration.
Monthly average 8 hr. /days below or only use occasionally	100 hr. or 1 month	200 hr. or 1.5 months	300 hr. or 2months	<ul style="list-style-type: none"> For reference only. Workplace conditions and environmental factors should also be taken into consideration.
Left unused for long time	Once every 2 months	Once every 3 months	Once every 4 months	<ul style="list-style-type: none"> Extended periods of inactivity may cause oil oxidation and rust on internal components. Before reuse, check internal parts and replace the oil. If rust is present, do not operate—contact the manufacturer.

7.6 Oil Selection

Please select the oil with adequate viscosity according to workplace environments to have best lubricity and protection.

Maintenance

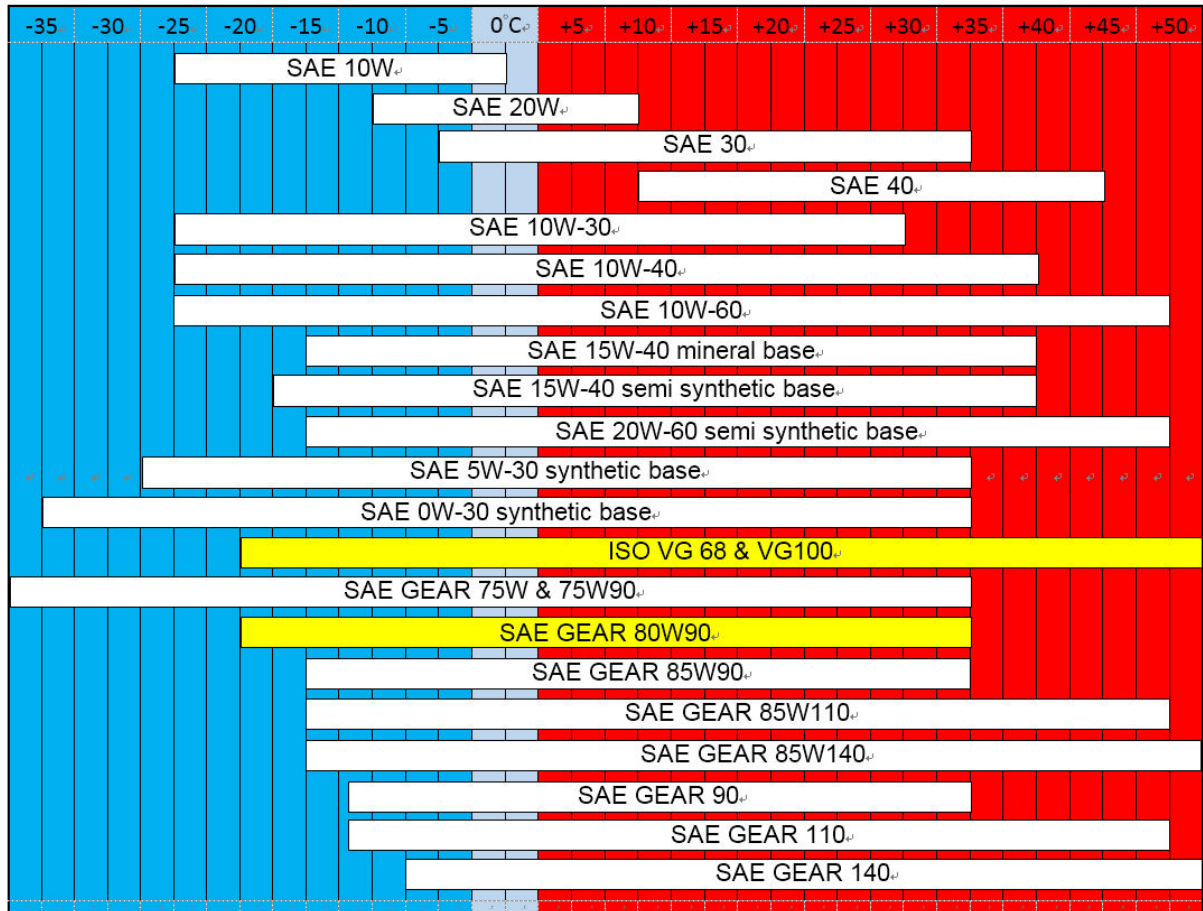

Viscosity Classification Equivalents

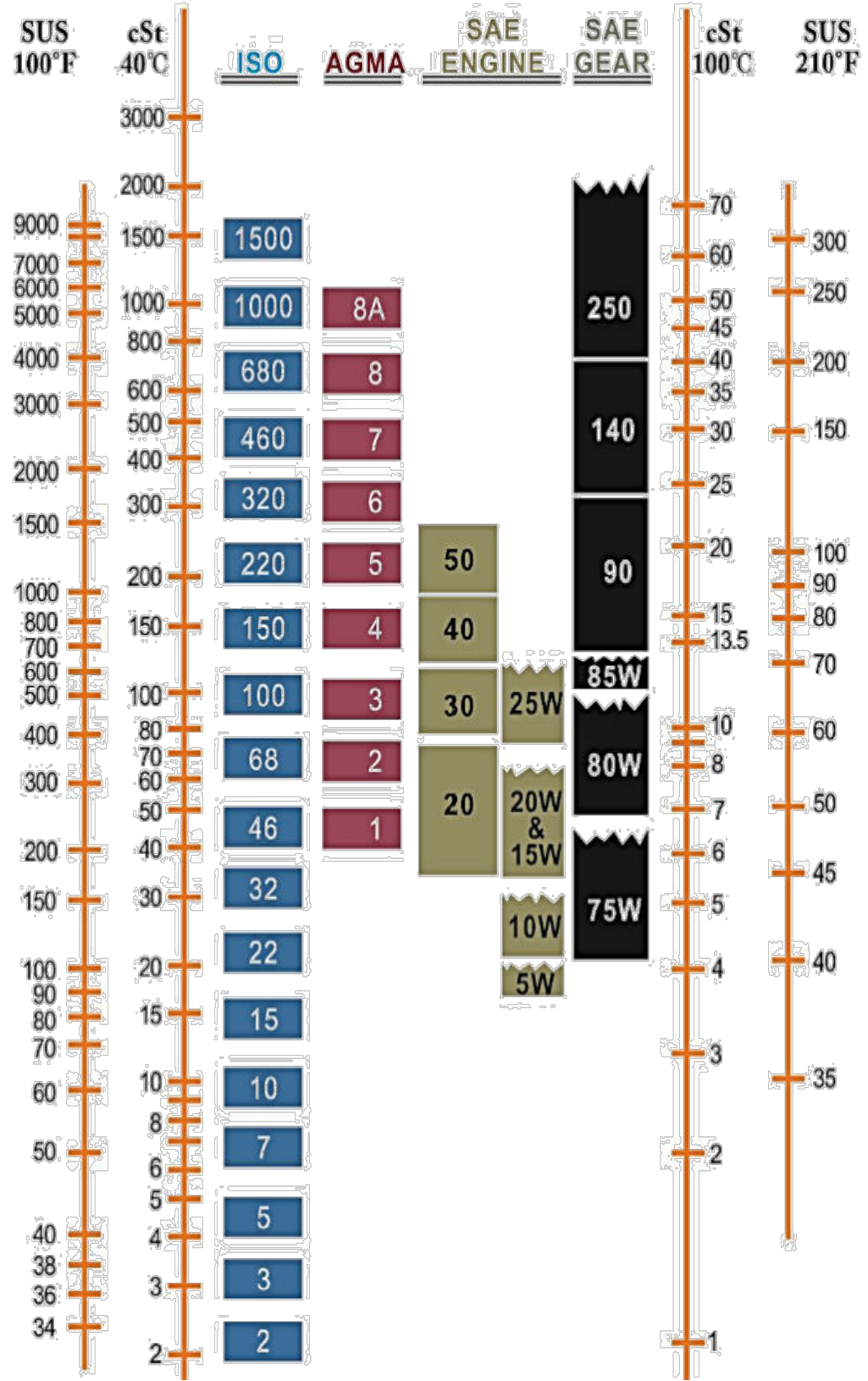

Maintenance

8. Warranty



DANGER

Please read the Operating Manual carefully before use.

8.1 Warranty content: If original parts are found defective in material or workmanship, warranty service may be requested according to the terms and period specified in this manual.

The warranty covers repair or replacement of defective parts. Any removed parts will become the property of Aeromist.

8.2 Warranty period: The warranty period is within one year from the delivery date.

8.3 Non-warranty items:

- Modifications or changes that our company does not recognize.
- Exceed the usage limit indicated by our company.
- Failure to regularly inspect or fail to comply with prohibited matters or storage methods.
- The machine has been repaired by unauthorized or untrained personnel after a malfunction.
- Use of non-original parts or other brand oils (lubricating oil) other than the original oil.
- Damage caused by natural factors, including time-related rust or natural disasters such as earthquakes.
- Additional costs incurred due to the unsuccessful use of the machine (such as: losses caused by closure, costs of renting other machines and operating losses, etc.)
- Issues that do not affect functionality and are based solely on user perception (e.g., sound, vibration, or minor cosmetic scratches).
- Machine failure caused by improper use or failure to follow the instructions in the Operation Manual.
- Filters, nozzles, pressure, high pressure pipes, oil seals and other related consumables.



CAUTION

- When requesting warranty, be sure to show this warranty, otherwise, the warranty repair will not be provided.
- Warranty repairs will not be accepted if the machine is used in environments containing asbestos, hazardous dust, or potential radiation exposure, as these conditions pose health risks to service personnel.

AEROMIST
SOLACE™
MISTING PUMP

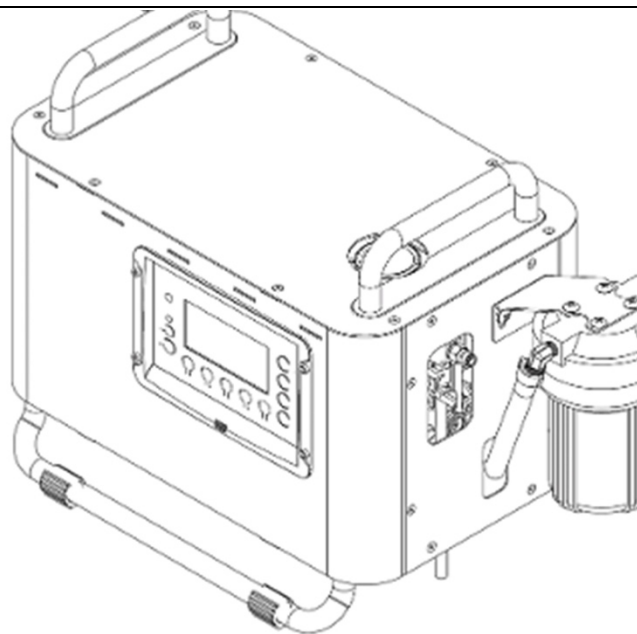

Contact Us



Customer Service



833-FOR-MIST (480-367-6478) Option 1



customerservice@aeromist.com



Technical Support



833-FOR-MIST (480-367-6478) Option 2



support@aeromist.com



Dealer Network



833-FOR-MIST (480-367-6478) Option 3



dealers@aeromist.com

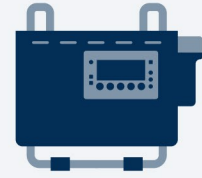

AEROMiST
SOLACE™
MISTING PUMP

Cool. Calm. Controlled.

PRODUCT MANUAL

 1-833-FOR-MIST

 SUPPORT@AEROMIST.COM

 AEROMIST.COM